

Protection Coordination in DC Grids

Motivation

DC grids become a largely research topic as numerous loads are operated using different DC voltage level. The protection of DC systems represent one of the main challenges which are faced with the development of such systems. In this context new protection concepts need to be developed and implemented based on experimental and simulation activities.

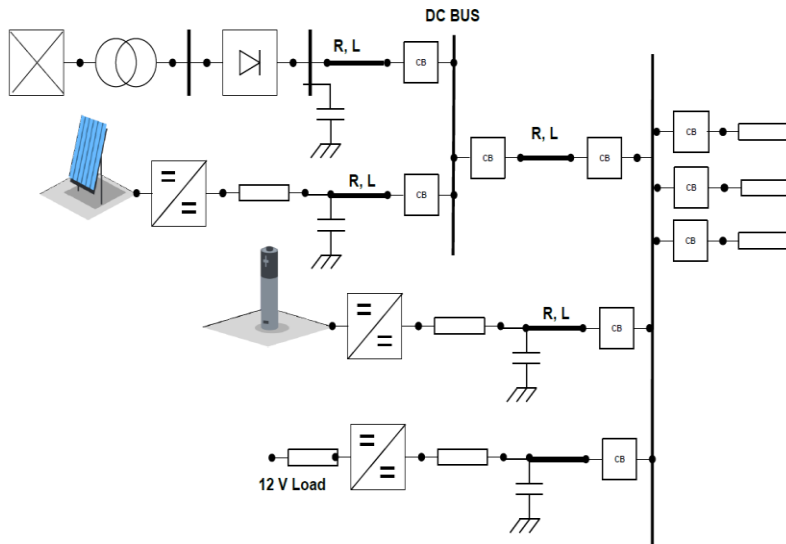

Objectives

- Identification of different DC grids topologies for different DC voltage levels.
- Developing of DC loads models in steady state and transients
- Proposing different protection coordination concepts in different DC voltage levels.
- Implementation of such concepts in the laboratory.

To these challenges and your own proposals within the scope of this subject I can supervise students (**Bachelorarbeit, and Masterarbeit**). Interested students can contact me at this email (n.hemdan@tu-braunschweig.de)